

# C 102

Control valves

Downstream stabilisers with two pilots

## Technical Data Sheet



## Description

The control valves C 102 controls and maintains a preset reduced downstream pressure regardless of variations in demand and upstream pressure (the setting of downstream pressure is always below the upstream pressure). Equipped with two identical pilot valves. The addition of a second pilot allows uninterrupted working while servicing one of the pilots or ease the change of a different pressure pilot setting. Equipped with check valves, it closes automatically in case of backflow (C102C). It allows the maintenance of a pilot while working.



## C 102

Control valves - Downstream stabilisers with two pilots

DN		PN	PFA in bar	PS				Cat	Ref.	Weight* Kg
"	mm			L1	L2	G1	G2			
1 1/2		10/16/25	25	25	25	x	x	4.3	<b>149B001363</b>	8
	40	10/16/25	25	25	25	x	x	4.3	<b>149B001364</b>	12
	50	10/16/25	25	25	25	x	x	4.3	<b>149B001365</b>	13
	65	10/16/25	25	25	25	x	x	4.3	<b>149B10206N</b>	21
	80	10/16/25	25	20	25	x	x	4.3	<b>149B10208N</b>	26
	100	10/16	16	16	16	x	x	4.3	<b>149B10210N</b>	39
	125	10/16	16	16	16	x	x	4.3	<b>149B10211N</b>	59
	150	10/16	16	16	16	x	x	4.3	<b>149B10212N</b>	73
	200	10	10	10	10	x	x	4.3	<b>149B10214N</b>	122
	250	10	10	10	10	x	x	I	<b>149B10215N</b>	208
	300	10	10	10	10	x	x	I	<b>149B10216N</b>	328
	200	16	16	10	16	x	x	4.3	<b>149B034310</b>	122
	250	16	16	10	16	x	x	I	-	208
	300	16	16	10	16	x	x	I	-	328
	100	25	25	20	25	x	x	4.3	<b>149B001371</b>	39
	125	25	25	16	25	x	x	4.3	-	59
	150	25	25	13	25	x	x	4.3	<b>149B047279</b>	73
	200	25	25	10	25	x	x	4.3	-	122
	250	25	25	10	25	x	x	I	-	208
	300	25	25	10	25	x	x	I	-	328

\* Weight of valve alone

### Important notice :

The indicated pressure for the different categories of fluids (L1/L2/G1/G2) is under no condition a guarantee of use. Therefore, it is essential to validate the use of products under given operating conditions.

Technical features	
Operating temperature	-10 °C to 90 °C
Upstream pressure	Mini. : 1 bar / Maxi. : 25 bar (see table above)
Connection	DN 40 to 300 mm : with flange PN (see table above) DN 1"1/2 : threaded F/F
Mediums	Clear water 2 mm
Vertical mounting	In optional

## Nomenclature and materials

N°	Description	Materials	EURO	ANSI
1	Membrane	EPDM / Polyamide		
2	Position indicator with purge	Brass and stainless steel	EN 12164-CuZn39Pb3-R360min EN 10088-3-X5CrNi18-10 EPDM Cu	ASTM B36 / ASTM B121 AISI 304 / ASTM A240
3	Valve head high pressure	Ductile iron / Epoxy Int/Ext	EN 1563 EN-GJS-400-15 except DN 125 : EN 1561-EN-GJL-300	ASTM A536 60-40-18 ASTM A48 class 45B
4	Nuts and bolts	Stainless steel	EN 10088-3-X5CrNi18-10	AISI 304 / ASTM A240
5	Removable streamlined	Stainless steel	EN 10213-GX5CrNi19-10+AT	AISI 304 / ASTM A240
6	Body drain plug	Brass	EN 12164-CuZn39Pb3-R360min	ASTM B36 / ASTM B121
7	Reversible seal	EPDM		
8	Body high pressure	Ductile iron / Epoxy Int/Ext 150µ ± 50µ	EN 1563 EN-GJS-400-15 except DN 125 : EN 1561-EN-GJL-300	ASTM A536 60-40-18 ASTM A48 class 45B
9-10	Valve	Chromed brass		
11	Stem	Stainless steel	EN10213-GX5CrNi19-10-AT	AISI 304 / ASTM A240
12	Flange	Stainless steel	EN10088-3X5CrNi18-10	AISI 304 / ASTM A240
13	Seal carrier	Bronze (DN40-50) Cast iron / Epoxy	EN1982 CuSn5Zn5Pb2-C GS EN1561-EN-GJL-250	ASTM A 48 35 B
14	Plate	Bronze (DN40-50) Cast iron / Epoxy	EN1982 CuSn5Zn5Pb2-C GS EN1561-EN-GJL-250	ASTM A 48 35 B
15	Spring	Stainless steel	EN10270-3 X10CrNi18-8	AISI 302

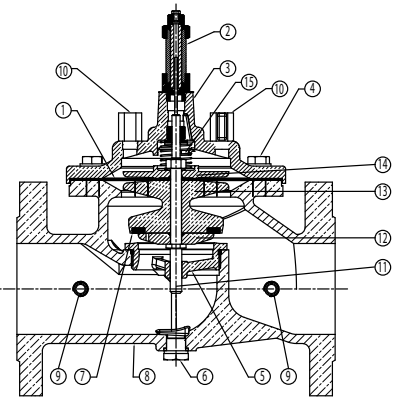

standard flow valve

## Approvals

ACS  PED 2014/68/UE

### International construction Standards :

Directive 2014/68/UE

Connection with flange PN according to EN 1092-2

## Application

The control valves C 102 reduces pressure in a distribution, irrigation or pump outlet system.

# Operation

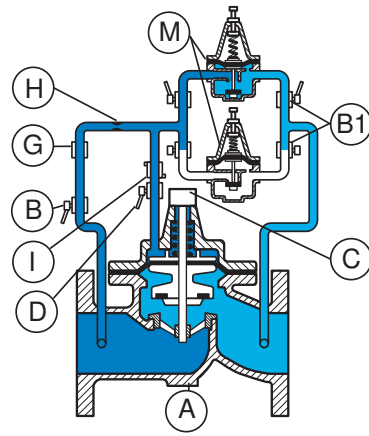
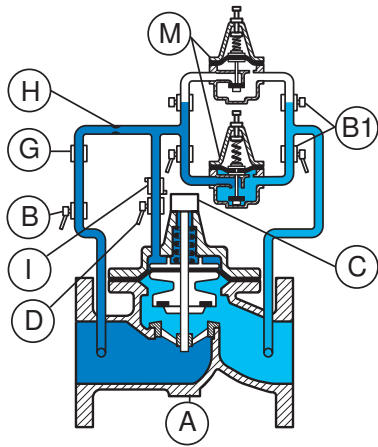

Type C102 works like a pressure reducing valve type C101. Only pilot (M) is working.

Only pilot (M) is working. Its setting can be different or similar to the setting of second pilot (M).

# Installation

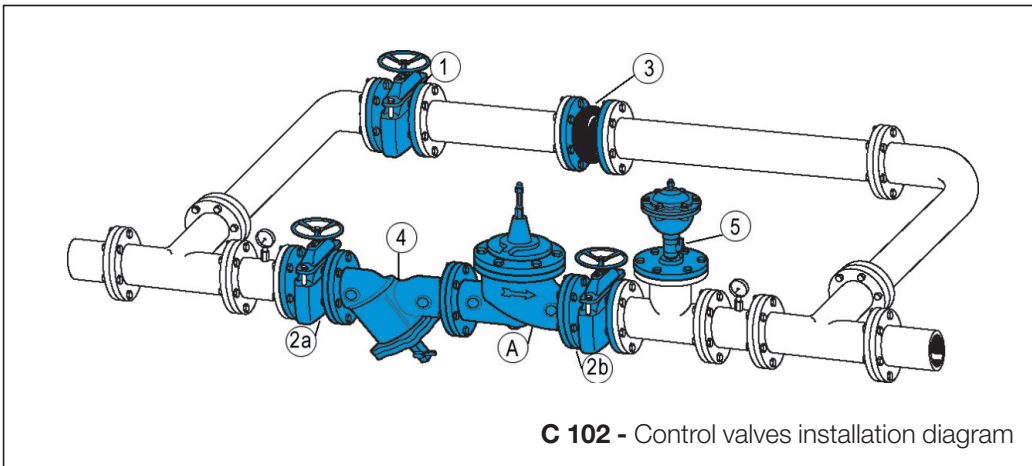

N°	Description
A	Main valve
B	Upstream isolation valve
B1	Downstream isolation valve
C	Position indicator with drain
D	Chamber isolation valve
G	Filter
H	Orifice-needle valve
I	Flow control
M	Pilot C101
1	Isolation valve of the by-pass
2a	Upstream isolation valve of the main water pipe
2b	Downstream isolation valve of the main water pipe
3	Rubber expansion joint
4	Filter
5	Single function air valve

**Setting range :**

- 0,4 to 5,51 bar
- 1,72 to 8,5 bar (standard)
- 2,06 to 24,5 bar

**Installation :**

- Install a strainer upstream
- Install an air relief valve down-stream or at the high point near the control valve
- Horizontal setting up : the cap of the valve should be oriented to the top and inclined at 45° maximum
- Vertical setting up : change the spring of the main valve (option 7)

**Other types :**

- C102S
- FKM seals in the main valve and in the pilot
- pilot stainless steel 304 and connection stainless steel 316TI

## Maintenance

---

We recommend a maintenance programme of between 6 to 12 months according to the quality of the water and to the pressure :

- Purging the upper chamber
- Flushing the valves not frequently used
- Checking and cleaning filters of the pilot circuit and main piping system.
- Checking the working (pressures)

Every 5 years, general maintenance is advisable :

- Dismantling
- Cleaning of main valve and pilot valve
- Preventive removing of the seals (set available - please consult us)
- Reassembling and tests.

# Operating characteristics

## Choice of base valve

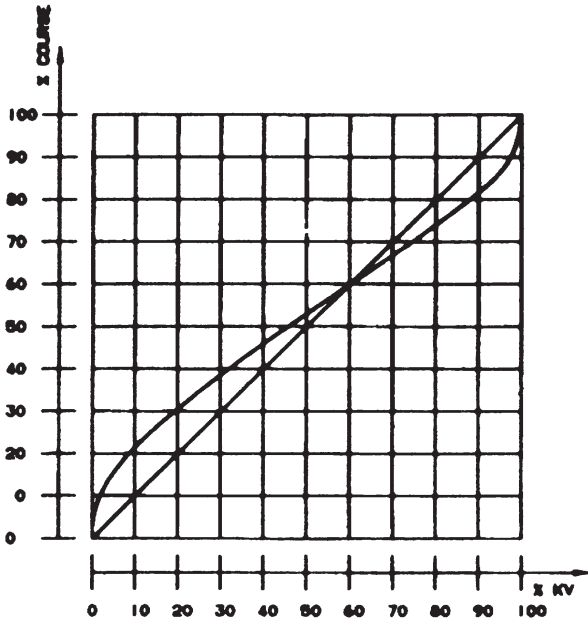

DN	Mini m <sup>3</sup> /h	Maxi m <sup>3</sup> /h	KV		ζ
			m <sup>3</sup> /h	L/s	
1" 1/2	0,520	20,34	26,35	7,32	5,78
40	0,675	32,00	45,66	12,68	1,93
50	0,675	32,00	45,66	12,68	4,70
65	0,855	54,00	57,75	16,08	8,39
80	1,600	82,00	80,00	22,22	10,00
100	2,720	127,00	136,00	37,78	8,47
125	4,400	199,00	220,00	61,11	7,90
150	5,280	286,00	264,00	73,33	11,38
200	13,500	509,00	600,00	66,67	6,96
250	25,000	795,00	900,00	50,00	7,56
300	40,900	1145,00	1224,00	40,00	8,47

## Headloss chart

Solid line: Base valve completely open

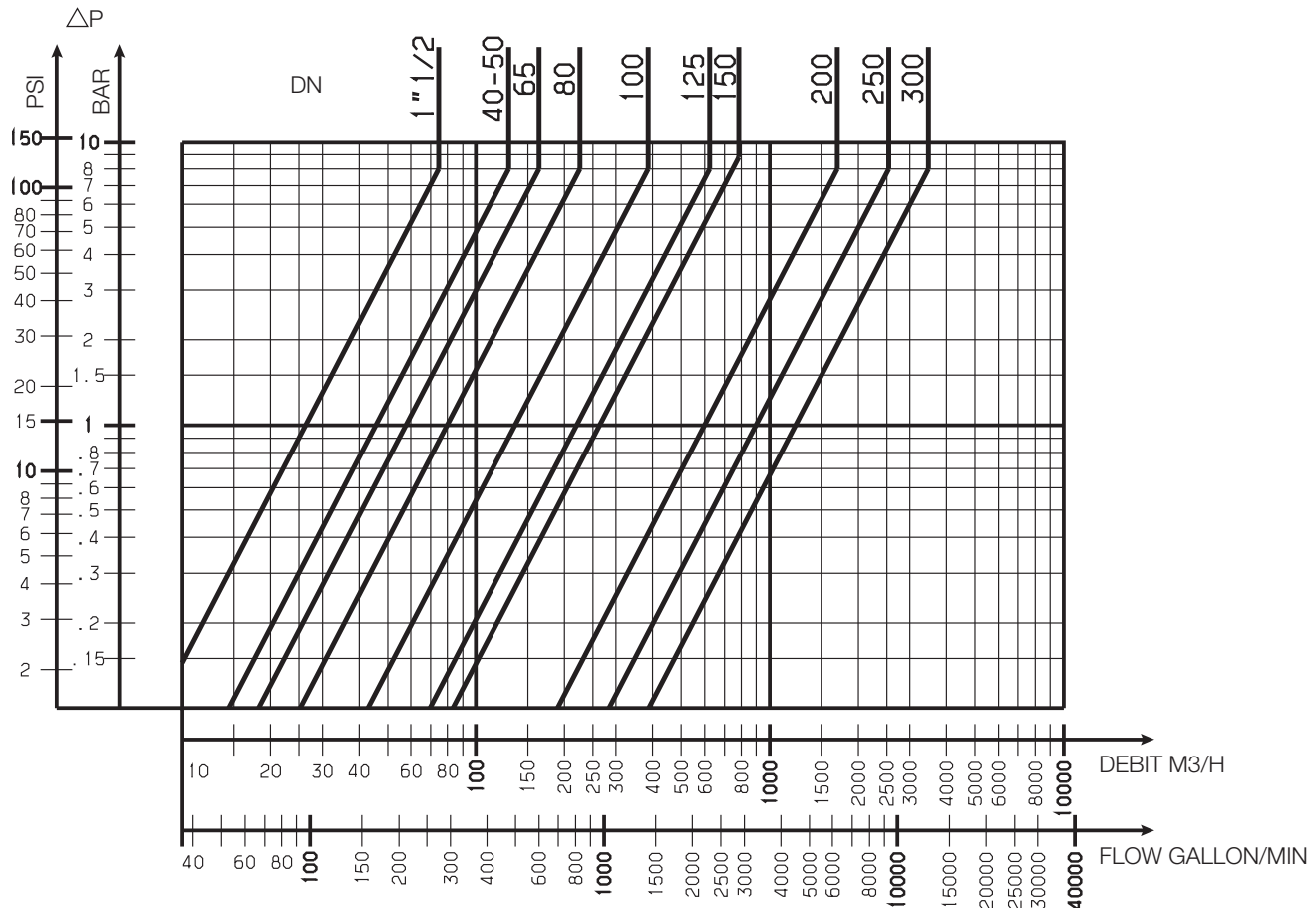

## Sizing

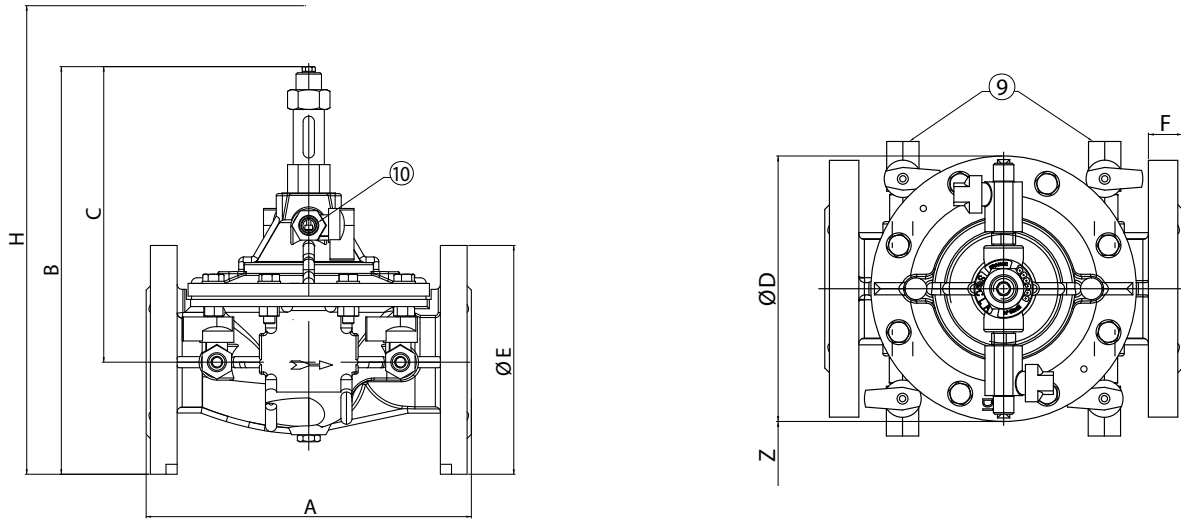

### standard flow valve

DN	A	B	C	Ø D	Ø E	F	H	Z	9	10
”	mm	mm	mm	mm	mm	mm	Exc. C501 mm	mm	”	”
1 1/2(F/F)	230	267	210	170	6 pans <sup>(1)</sup>	-	400	254	1/4	3/8
40	230	285	210	170	152	23	400	254	1/4	3/8
50	230	285	210	170	161	23	400	254	1/4	3/8
65	290	352	257	200	185	24	470	254	3/8	1/4
80	310	372	272	217	200	26	500	254	3/8	3/8
100	350	423	302	241	235	28	510	254	3/8	3/8
125	400	506	371	296	270	30	570	254	3/8	3/8
150	480	551	401	363	300	20	650	254	3/8	3/8
200	600	709	529	467	360	22	750	254	3/8	3/8
250	730	844	631	587	425	24	900	254	1/2	1/2
300	850	975	730	680	486	27	1100	254	1/2	1/2

(1) 78/plats

## Other operating characteristics

### Cavitation

A too large differential pressure and a low downstream pressure may result in damage to the valve by cavitation.

To avoid it, refer to the cavitation curve and if needed, reduce the differential pressure by installing and connecting two or more control valves in same line (consult us).

Stainless steel seat and counter seat are standard.

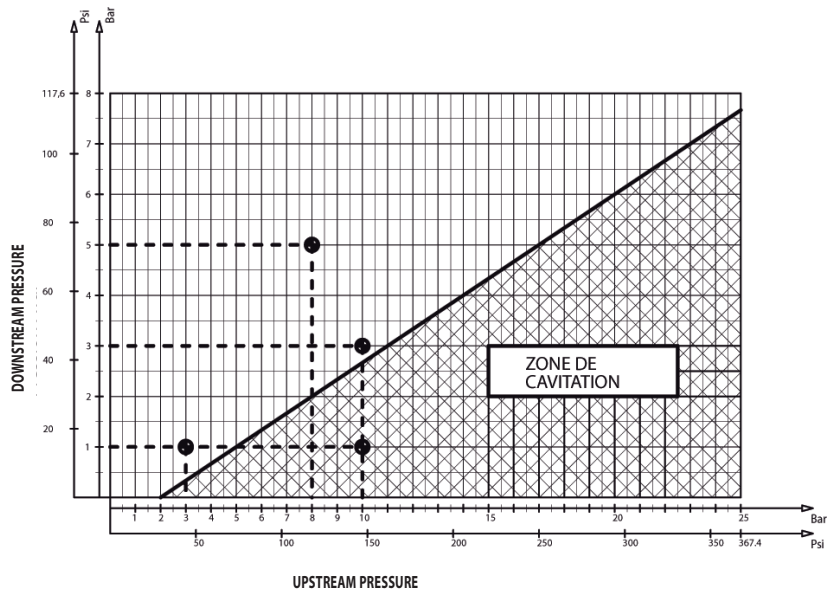

The descriptions and photographs contained in this product specification sheet are supplied by way of information only and are not binding.

Socla reserves the right to carry out any technical and design improvements to its products without prior notice. Warranty : All sales and contracts for sale are expressly conditioned on the buyer's assent to Socla terms and conditions found on its website at [www.socla.com](http://www.socla.com). Socla hereby objects to any term, different from or additional to Socla terms, contained in any buyer communication in any form, unless agreed to in a writing signed by an officer of Socla.



A WATTS Brand

Socla sas

365 rue du Lieutenant Putier • 71530 Virey-Le-Grand • France

Tel. +33 03 85 97 42 00 • Fax +33 03 85 97 42 42

[contact@wattswater.com](mailto:contact@wattswater.com) • [www.socla.com](http://www.socla.com)

ISO 9001 version 2015 / ISO 18001